



# Thomas Keating Ltd

Station Mills, Daux Road  
Billingshurst, West Sussex  
ENGLAND. RH14 9SH

Tel: +44 (0) 1403 782045 Fax: +44 (0) 1403 758464

[www.terahertz.co.uk](http://www.terahertz.co.uk)

User Manual	<b>Gaussian Beam Mode 3D Engine</b> <i>(running within PTC's Creo Parametric 2.0)</i>		
Version	<b>4.1</b>	Date	<b>29<sup>th</sup> July 2014</b>

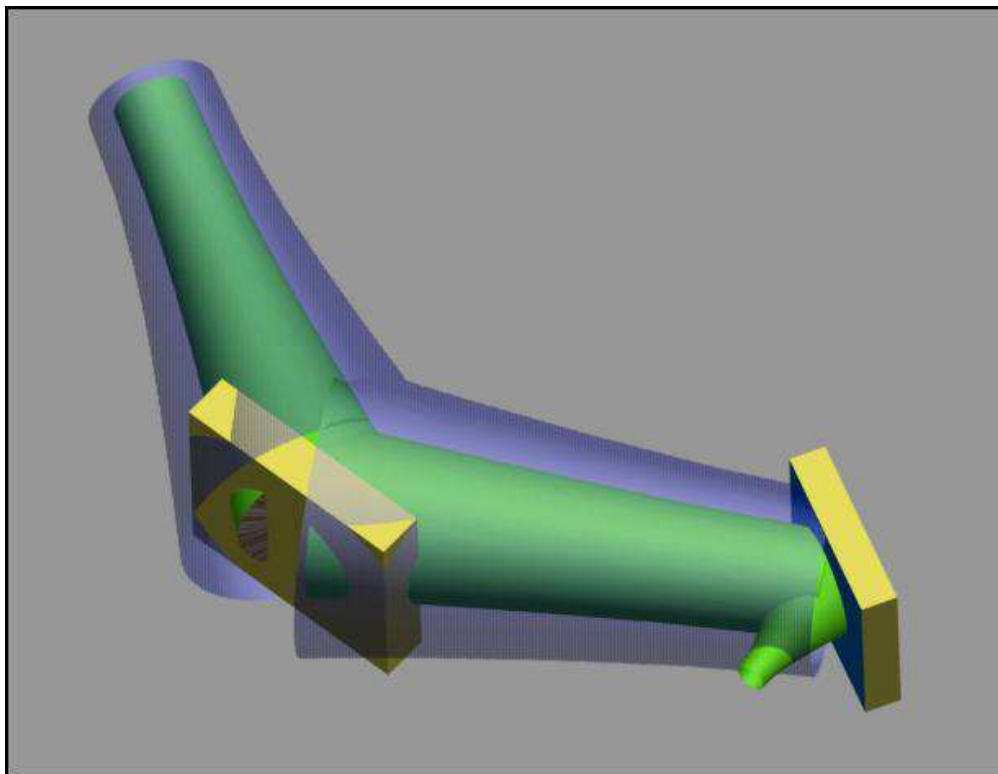

This manual is copyright. All rights are reserved.

The document may not, in whole or in part, be copied, photocopied, reproduced, translated or reduced to any electronic medium or machine readable form without prior consent, in writing, from Thomas Keating Ltd

Registered in the UK No. 00203511

**Copyright © Thomas Keating Ltd. 2011-2014**

<b>SOFTWARE</b>	<b>3</b>
<b>1 THE GBM MANUAL</b>	<b>4</b>
1.1 THE BASE CAD SOFTWARE	4
1.2 QUASI-OPTICS AND GAUSSIAN BEAM-MODES	4
1.3 MIRRORS AND MIRROR DISTORTION	6
1.4 DESIGNING AND ERROR ANALYSIS	7
1.5 USING PRO/ENGINEER	9
1.6 3D GBM EXAMPLES	10
1.7 INTRODUCTION TO GAUSSIAN BEAM MODES	12
1.8 3D BEAM FUNCTIONALITY	13
<b>2 GETTING STARTED</b>	<b>15</b>
2.1 CREATING A NEW ASSEMBLY	15
<b>3 ASSEMBLE GBM COMPONENTS</b>	<b>16</b>
3.1 FIRST BEAM	16
3.2 MIRROR ASSEMBLY	18
3.3 BEAM ASSEMBLY FROM A MIRROR	19
3.4 FINISHED ASSEMBLY	20
<b>4 CONFIGURATION - ADDING FLEXIBILITY</b>	<b>21</b>
4.1 BEAM PARAMETERS	21
4.2 MAKING BEAMS FLEXIBLE	22
<b>5 FOCUSING MIRROR</b>	<b>24</b>
<b>6 MAKING MIRRORS FLEXIBLE</b>	<b>25</b>
<b>7 OUTPUT MATCHED BEAM</b>	<b>27</b>
<b>8 FINAL BEAM (TK-GBM-BEAM-A_XXX)</b>	<b>28</b>
<b>9 WAVELENGTH PARAMETER</b>	<b>29</b>
<b>10 ANALYSIS DISPLAY</b>	<b>31</b>
<b>11 BEAM WAIST FINDING BEAM</b>	<b>32</b>

Manual Change Record

Version	Date	Remarks
1.0	26/11/2007	Draft release
2.0	09/07/2010	First Edition
3.0	21/04/2011	Second Edition
4.0	07/07/2014	Third Edition update to Creo Parametric 2.0
4.1	29/07/2014	Expanded explanation of operation

## ***SOFTWARE***

Thomas Keating Ltd software and its accompanying documentation are sold on an 'as is' basis and no warranty is given or implied as to its fitness or suitability for any particular purpose. However, Thomas Keating Ltd will endeavour to rectify any errors found.

Comments on this manual and the accompanying software are welcome and can be sent to:

Stuart Froud - s.froud@terahertz.co.uk

Richard Wylde - r.wylde@terahertz.co.uk

Thomas Keating Ltd ©2014

## 1 THE GBM MANUAL

The Gaussian Beam Mode software uses the flexibility and assembly functionality residing within Pro/Engineer (Creo Parametric 2.0):

### 1.1 THE BASE CAD SOFTWARE

By creating an assembly it is possible, by using our routines, to make changes to just one model, the wavelength for example, and the effect of that change is propagated throughout the rest of the assembly.

It is assumed that the user has a strong practical knowledge of Creo Parametric 2.0<sup>1</sup>. This is necessary to get the most out of this manual and accompanying 3D models and assemblies.

### 1.2 QUASI-OPTICS AND GAUSSIAN BEAM-MODES

In addition, to use this software to design and validate Quasi-Optical systems requires a broad understanding of the corpus of knowledge that lies behind Gaussian Beam-mode analysis.

A good starting point is:

*Paul F. Goldsmith "Quasi-optics" Institute of Electrical & Electronics Engineering (January 1994)  
ISBN 978-0780304116*

the user should be familiar with antennas which form Gaussian Beams - in particular:

*"Millimetre Wave Gaussian beam-mode Optics and Corrugated Feed Horns" Wylde, R.J., Proc. IEE  
Vol 131, p.258 Pt.H 1984*

and the recently developed Ultra-Gaussian Feedhorns

*"Reducing Standing Waves in Quasi-Optical Systems by Optimal Feedhorn Design"  
Paul A.S. Cruickshank, David R. Bolton, Duncan A. Robertson, Richard J. Wylde,  
Graham M. Smith, Joint 32 Int. Conf. Infrared and Millimeter Waves, and 15th Int.  
Conf on Terahertz Electronics, Cardiff, Sept 2007 Vol 2 p 941-942*

which can generate 99.88% pure Gaussian beams.

Essentially the software codes for standard fundamental mode Gaussian beams. You can see the presence of the beamwaist expansion formula (For example 2.21b in Goldsmith above) in the code attached to the model element in the image below

---

<sup>1</sup> Higher editions of Pro/E (Creo Parametrics 3.0 coming soon) are expected to work with these assemblies, but this cannot be guaranteed. Backwards compatibility is unlikely.

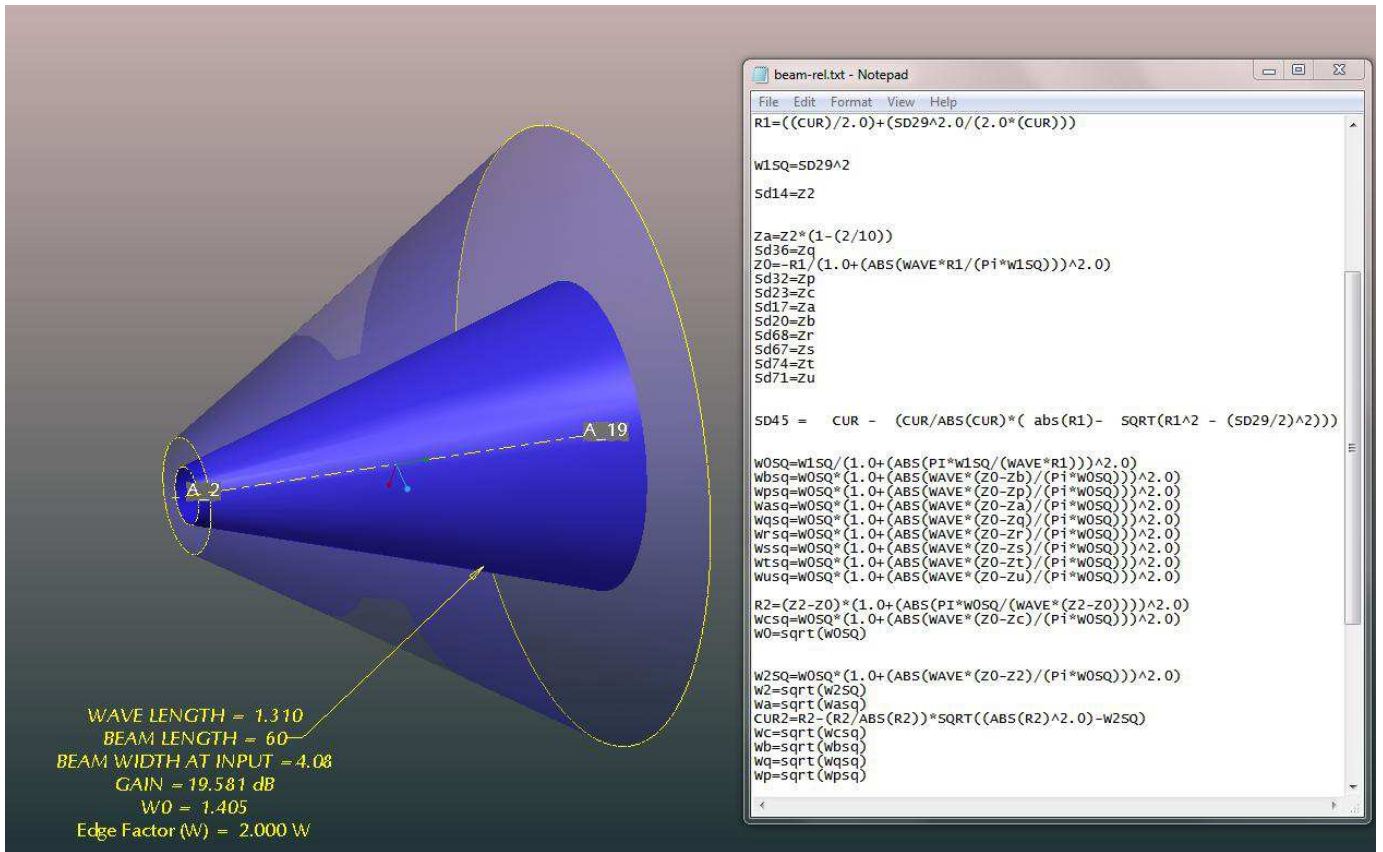

Fig 1 - 1 A Gaussian Beam Mode assembly and the code which lies behind it

### 1.3 MIRRORS AND MIRROR DISTORTION

Parameters for the manufacture of conic section mirrors can be taken from the displayed curvatures ( $R_e$ ,  $R_i$ ) and bend angles. Here part of a multiplexer circuit for a satellite radiometer is displayed

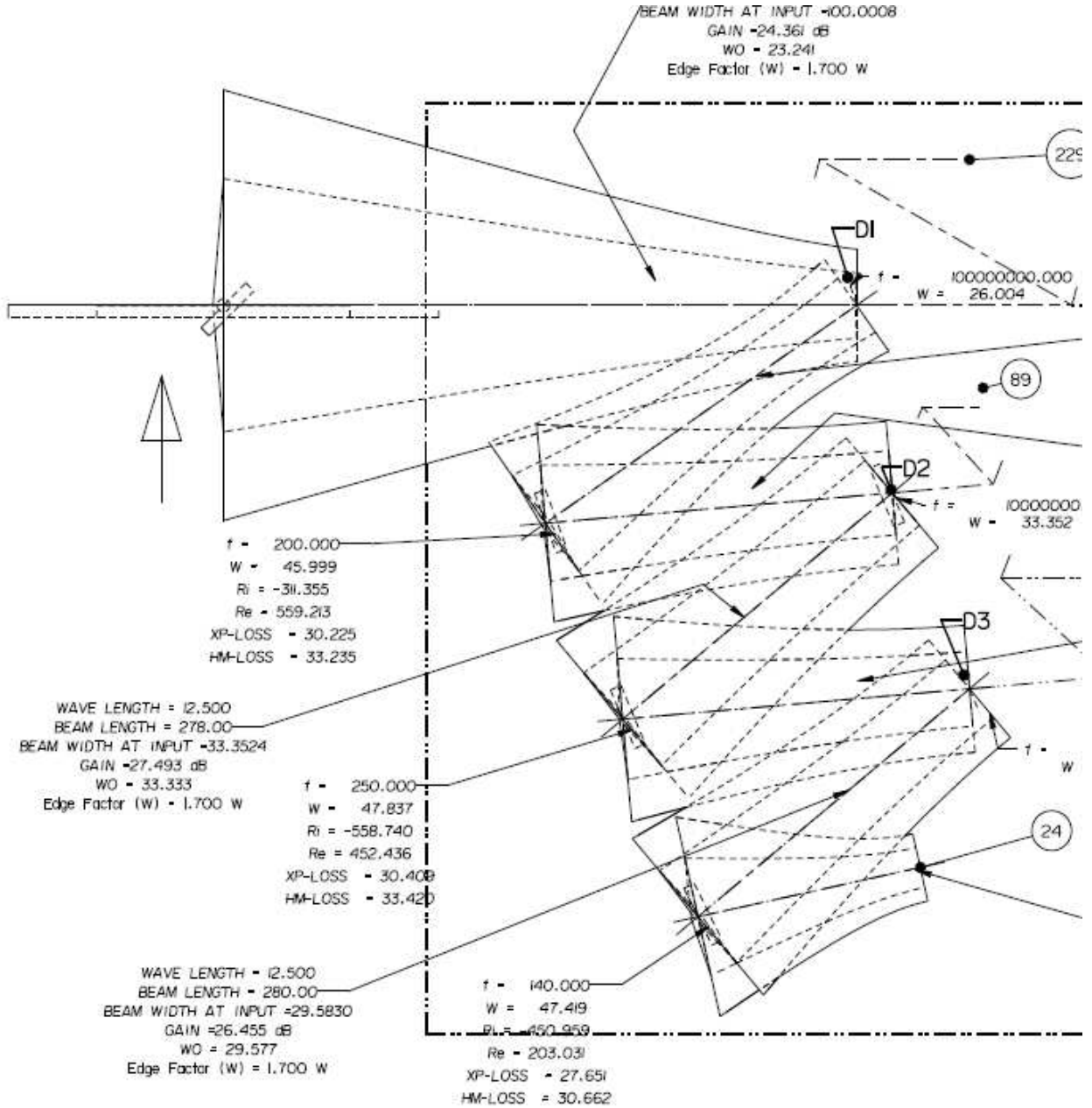

Fig 1 - 2 A 2D plot of beams. The outer contour is set to 1.7 times the beamwidth.  
Note the display of  $R_i$  and  $R_e$  curvatures associated with mirrors.

Users should understand the nature of beam distortion caused by off-axis mirrors by reviewing

*"Distortion of a simple Gaussian beam on reflection from off-axis Ellipsoidal Mirrors"*  
Murphy J.A., *Int. J. Infrared and Millimetre Waves*, 8 (9), pp 1165-1188, 1987

Distortion - both into Cross polar (XP-LOSS) and into higher-order modes (HM-LOSS) can be displayed by the software (see section 10 to learn how to switch this feature on), based upon formulae taken from Prof. Murphy's paper. This can be very valuable in determine the quality of the expected circuit: If loss at the -34dB are observed, other errors may well dominate. If, in contradistinction, loss at the -16dB level are seen, then the circuit is likely to be a poor one.

#### 1.4 DESIGNING AND ERROR ANALYSIS

Our GBM routine are essentially a design rather than a validation tool: When a Quasi-Optical circuit is properly constructed, the Creo CAD circuit can be very quickly modified to look at the effect of changing optical parameters within the circuit - e.g. focal length, beam angles and distances.

As an example, here is an image of a multi-beam antenna feed for Plasma Fusion diagnostics at JET in the UK. The first circuit show beams passing from an HE11 guide towards the plasma. Unfortunately the top mirror is too small from the expanding beam, as can be seen clearly.

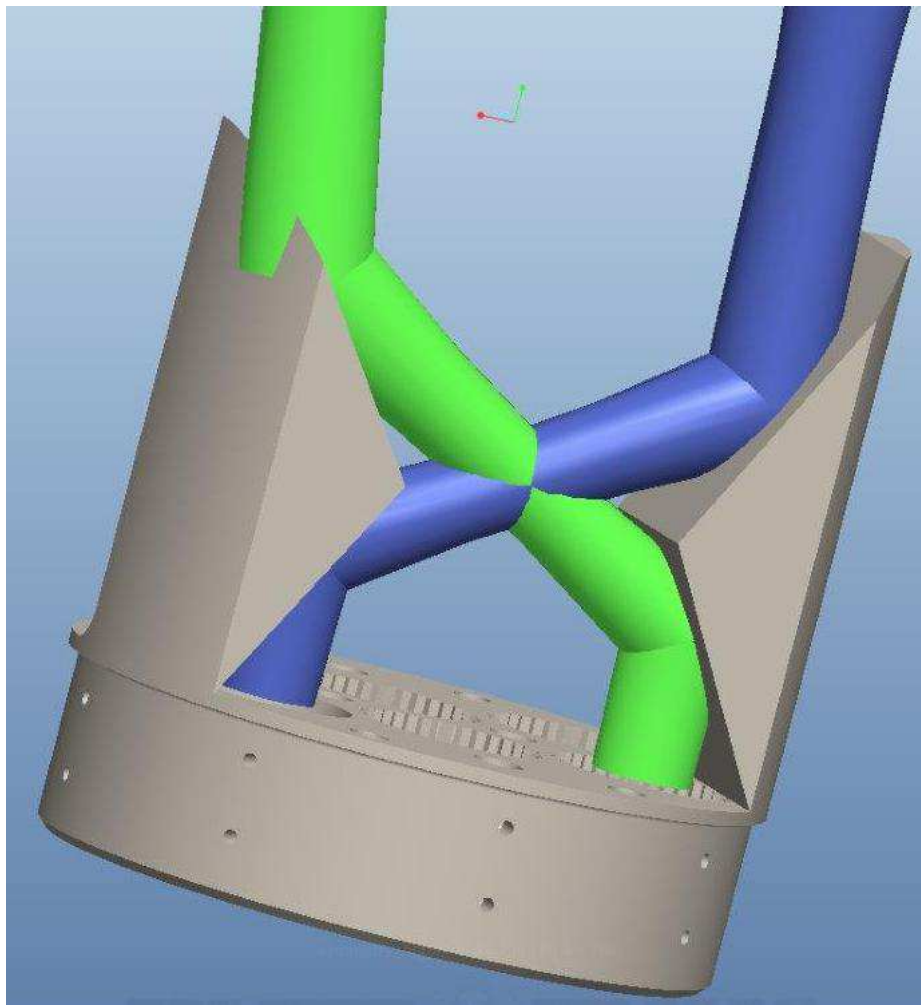

*Fig 1 - 3: the green beam is too large for the mirror*

Adding curvature to the two lower mirrors allows a beamwaist to be formed in the beam path and the top mirror now covers the beam to (in this case, the  $1/e^2$ ) in power.

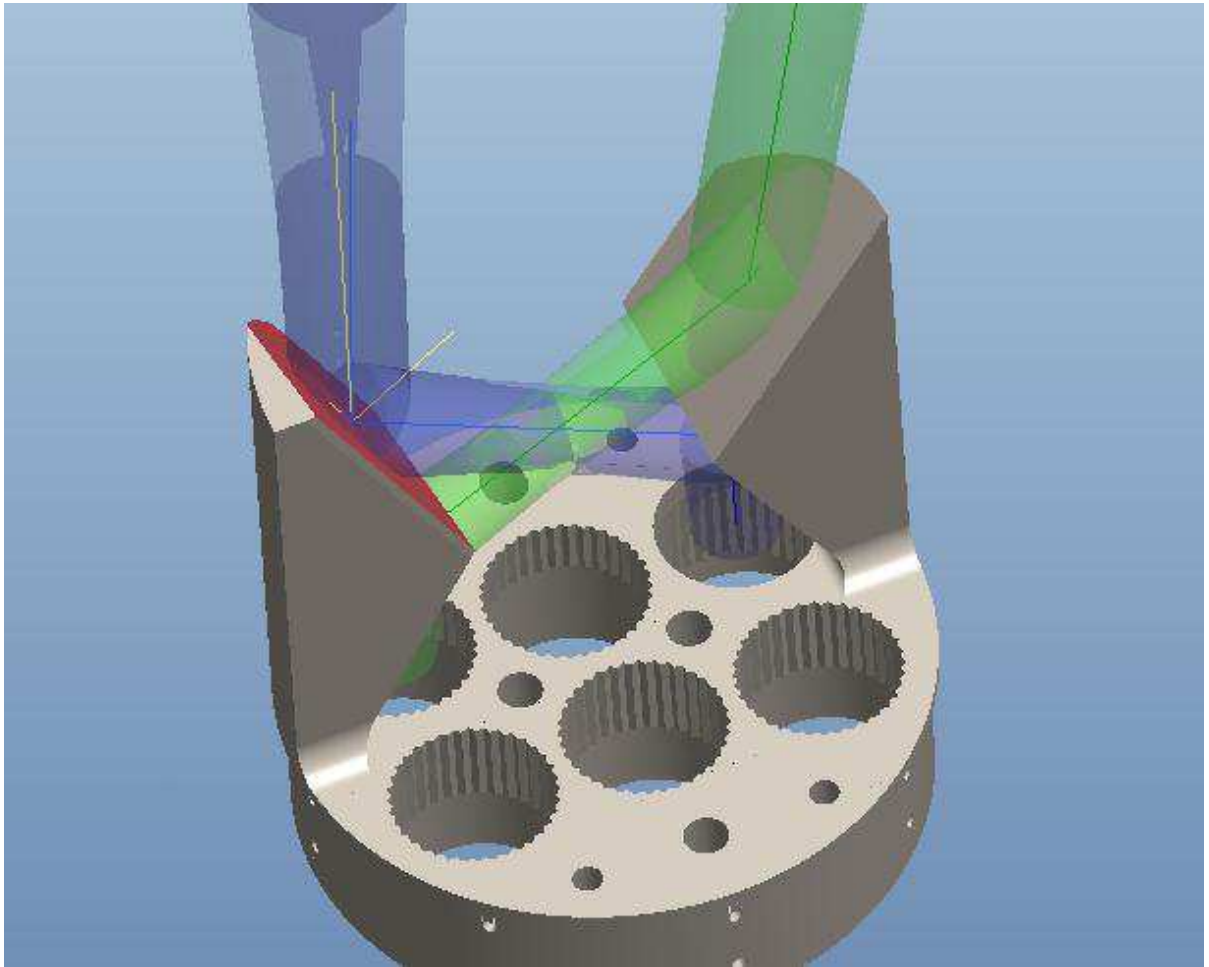

*Fig 1 - 4 ... but adding curvature on the lower mirrors fixes the problem*



## 1.5 USING PRO/ENGINEER

As with most CAD software, alternative methods can achieve the same results. This is certainly true in the case of using Pro/Engineer.

This manual describes one method of setting out 3D Gaussian beams and focussing mirrors from an empty assembly. By adding flexibility to parameters in such a way that links these models together, beam propagation can be displayed.

Also the renaming of beam models (see note below) will be necessary to create multiple, similar layouts that can function independently from other assemblies.

In the future you may want to create your own mapkey routines and use the 'repeat' functionality to enhance your assembly techniques.

Throughout this manual, unless otherwise stated, all selections are carried out with the left hand mouse button (LMB).

**NOTE:** When creating more than one assembly we recommend you first 'save a copy' of your assembly and rename both the assembly and the 'beam' model to a new name e.g.

*'TK-GBM-BEAM-ASSY-A\_xxx.prt' change to 'TK-GBM-BEAM-ASSY-A\_yyy.prt',*

*'TK-GBM-BEAM-A\_xxx.prt' change to 'TK-GBM-BEAM-A\_yyy.prt'*

*and*

*'TK-GBM-BEAM-Z0\_xxx.prt' change to 'TK-GBM-BEAM-Z0\_yyy.prt'*

Then start to re-edit your newly renamed assembly which will contain the renamed 'beam' parts.

By doing this you can avoid certain pit falls associated with Creo models having the same name.

## 1.6 3D GBM EXAMPLES

The following shows a few examples of the 3D Gaussian Beam Mode (GBM) beams that have been used at Thomas Keating, and assembly Fig 1-7 to 1-9 is provided as an assembly to form as part of this package.

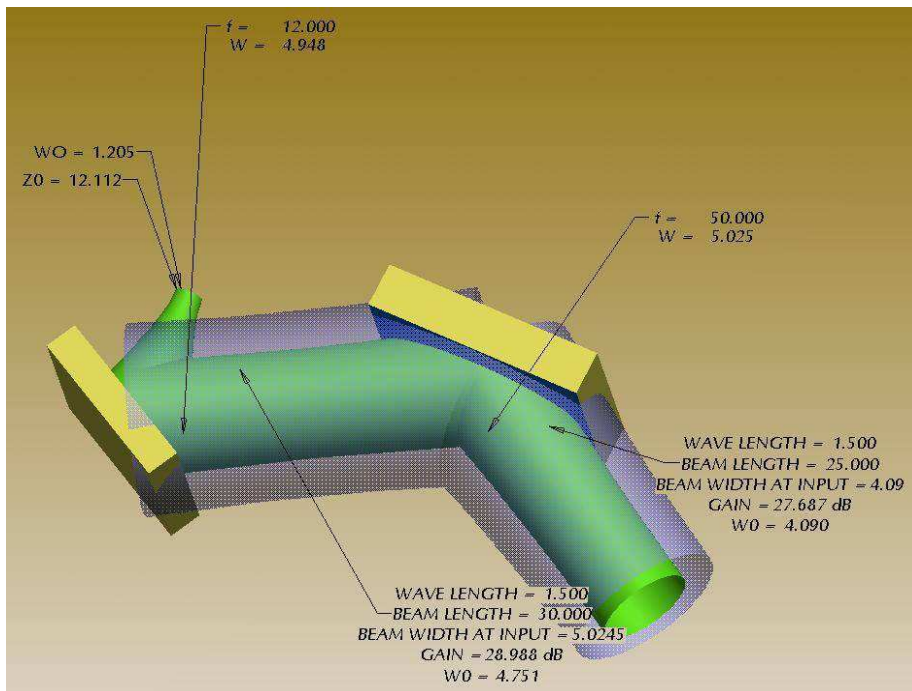

Figure 1-4 A simple beam path with two focussing mirrors

Here the beamwaist  $W_0$  and beamwidth  $W$  are displayed. The focal length,  $f$ , is taken from the thin lens formula ( $1/f = 1/R_{in} + 1/R_{out}$ ). Gain is taken for a fundamental Gaussian and is the far-field peak power on boresite divided by the far-field power if the antenna radiated isotropically

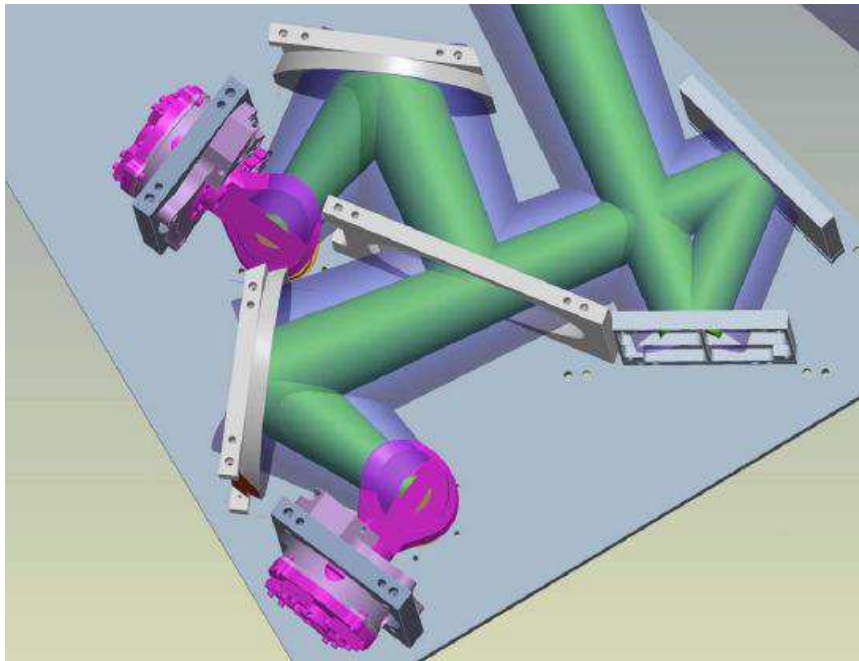
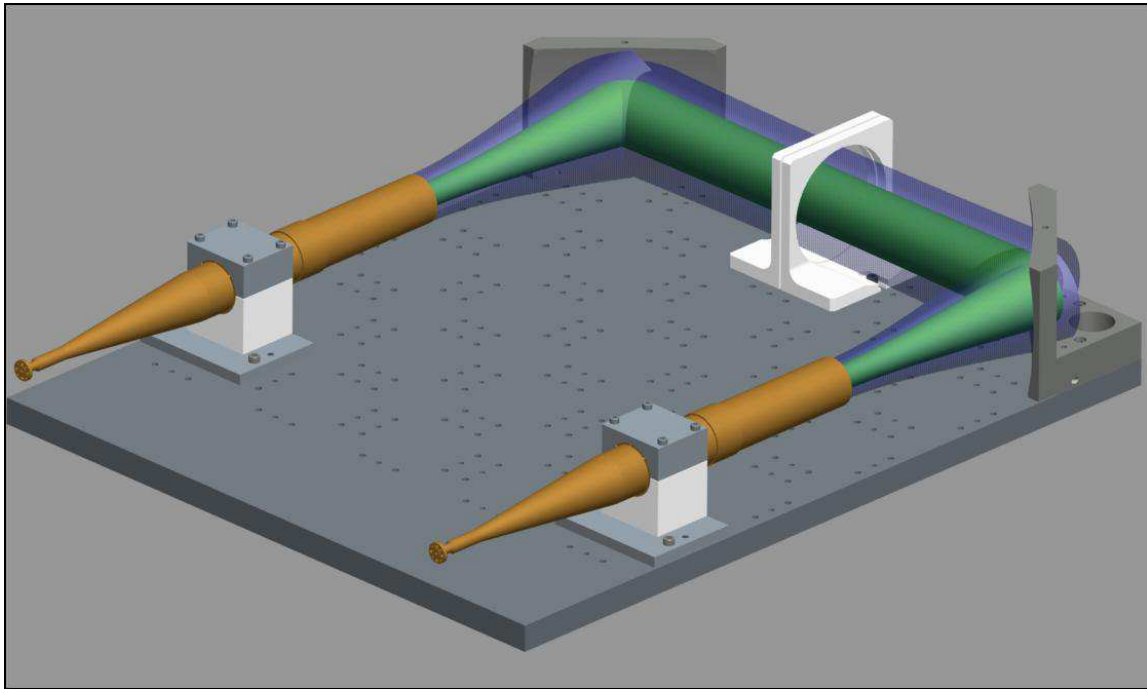

Figure 1-5 Path of beams in the Breadboard optics for JAXA's 94 GHz pulsed radar instrument on EarthCARE - Space Mission

One of the benefits of the use of these routines is that they allow a full integration of an electromagnetic and mechanical model – allowing easy detection of mechanical conflicts with the beams.



*Figure 1-6. Beam assembly included with this manual.  
Inner green beam - at  $W$  radius, and  $1.5W$  radius level in blue passing through a QO bench for material measurement*

It is possible to define different beam radii – and Edge Factor - (in units of  $W$ , the  $1/e$  amplitude width parameter), allowing the user to determine the level at which mechanical truncation occurs.

## 1.7 INTRODUCTION TO GAUSSIAN BEAM MODES

Fundamental Gaussian beam-mode analysis is a powerful tool for analysing the propagation of paraxial beams of radiation whose wavelength is no more than a few times smaller than the beam's cross section diameter.

In brief, a propagating beam can be described by two parameters:

- ▶ Beam width (W)
- ▶ Phase front curvature (1/R)

which vary along the axis of propagation. For any propagating beam there is a point on the beam axis, called the beam waist, where the beam width is of minimum size, and the curvature of the beam is infinite (the beam has a parallel phase front). These two parameters can be represented graphically by three points in any particular cross section. The centre point lies on the axis of propagation, while the other two lie either side of the axis. The distance of the outer points away from the axis represents the width of the beam to the 1/e amplitude contour. The curvature of the beam is represented by the longitudinal translation of the outer points with respect to the inner point, so that the phase front of the beam passes through all three points.

In three dimensions, this form describes a hemispherical cap.

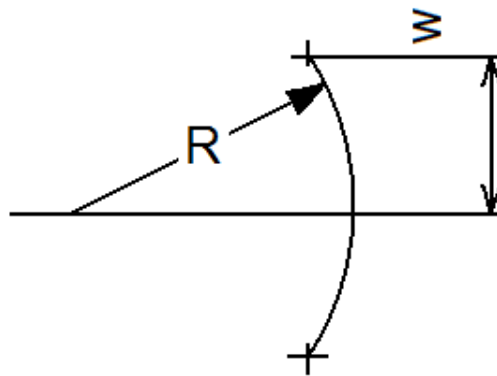

Figure 1-1 Three point representation

We choose to define W, the beam size, as given by the 1/e amplitude radius, which corresponds to -8.68dB level power.

It is worth noting that the power level at the edge of the beam, of radius r is also the fraction of power for a pure Gaussian that lies outside of the radius. i.e.

$$\frac{2\pi \int_r^\infty e^{-2\frac{r^2}{W^2}} r dr}{2\pi \int_0^\infty e^{-2\frac{r^2}{W^2}} r dr} = e^{-2\frac{r^2}{W^2}}$$

Figure 1-2 Equation

So that, for example, truncating at the -20dB level will leave 1% of the power outside of the beam.

## 1.8 3D BEAM FUNCTIONALITY

This manual will guide you through the assembly of 3D beams and mirrors as in the assemblies shown below.

Once an assembly has been completed, you will be able to change a parameter associated with a beam or mirror - such as the wavelength - and watch the effect propagate throughout your assembly.

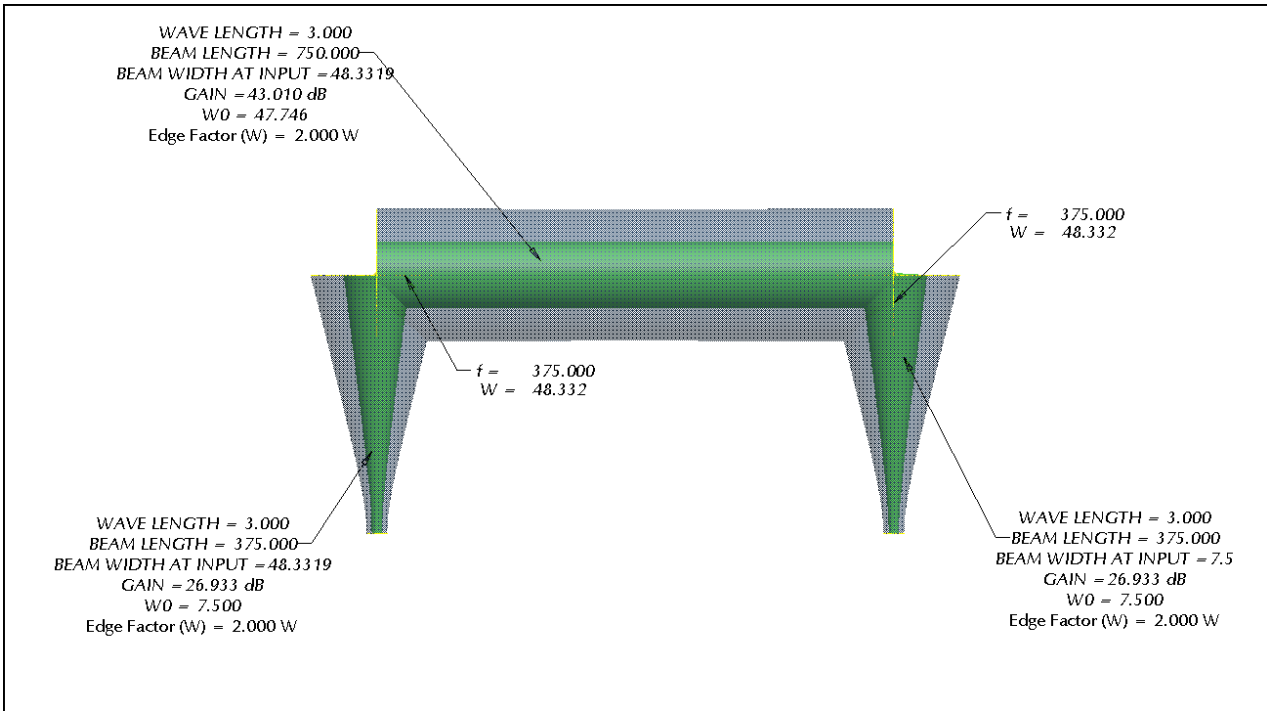

Figure 1-7 Wavelength set to 3mm

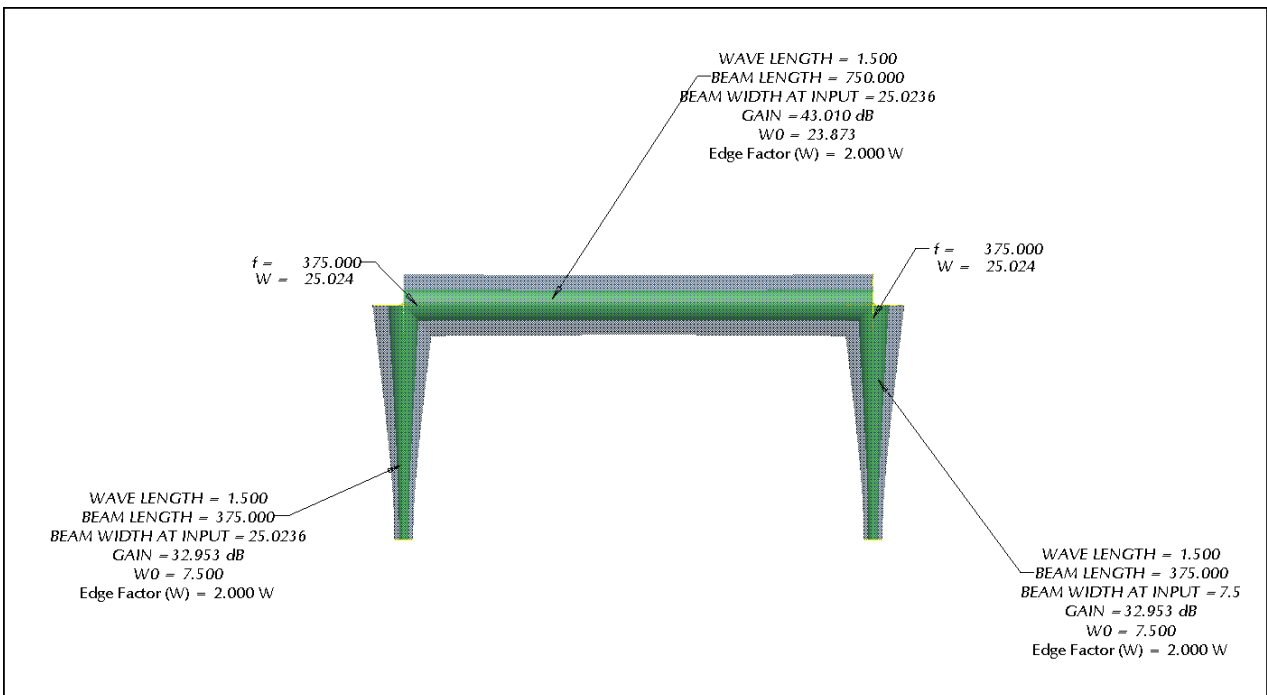

Figure 1-8 The effect from changing the wavelength from 3.0 to 1.5mm

You can see from the image below, by changing just one parameter; in this case the focal length of the first mirror from 375mm to 125mm (red arrow), the affect this has on the rest of the beam path.

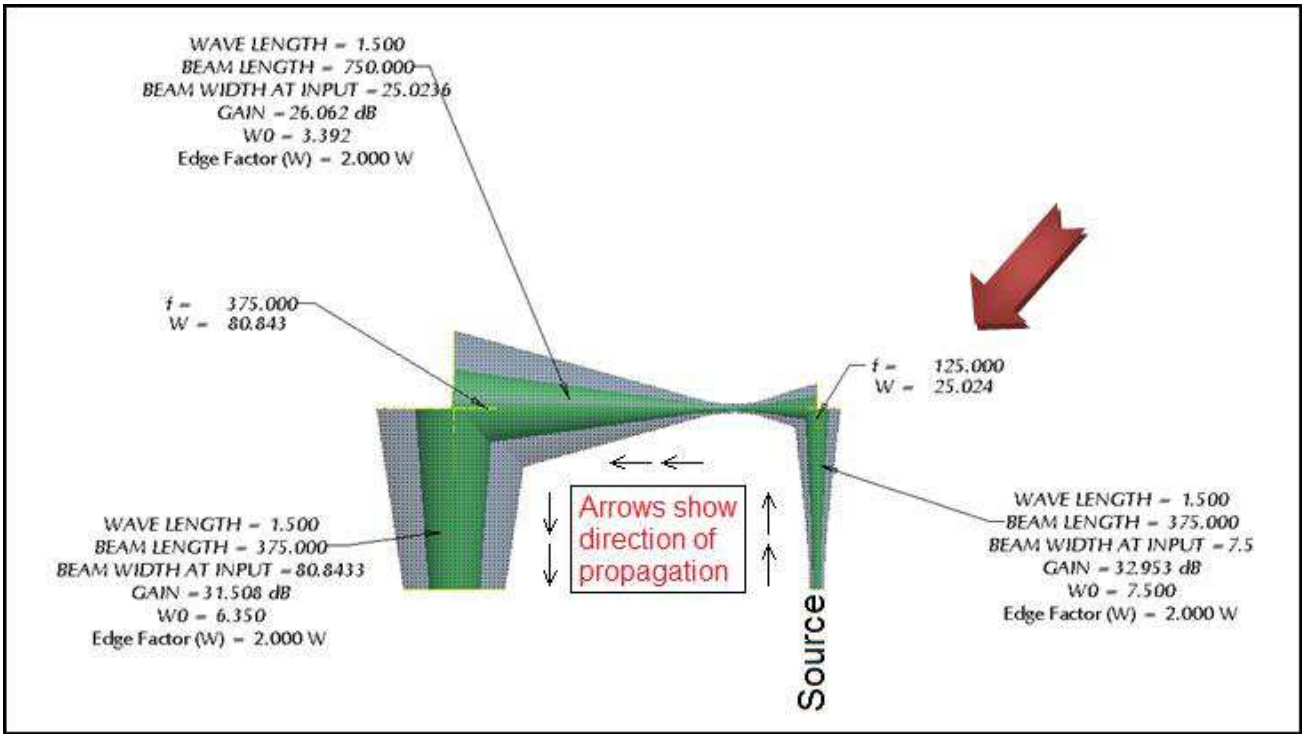

Figure 1-9 What happens when you change one of the focal lengths?

## 2 GETTING STARTED

We illustrate the process by constructing the optics of a simple QO material test bench, similar to the photograph shown below.

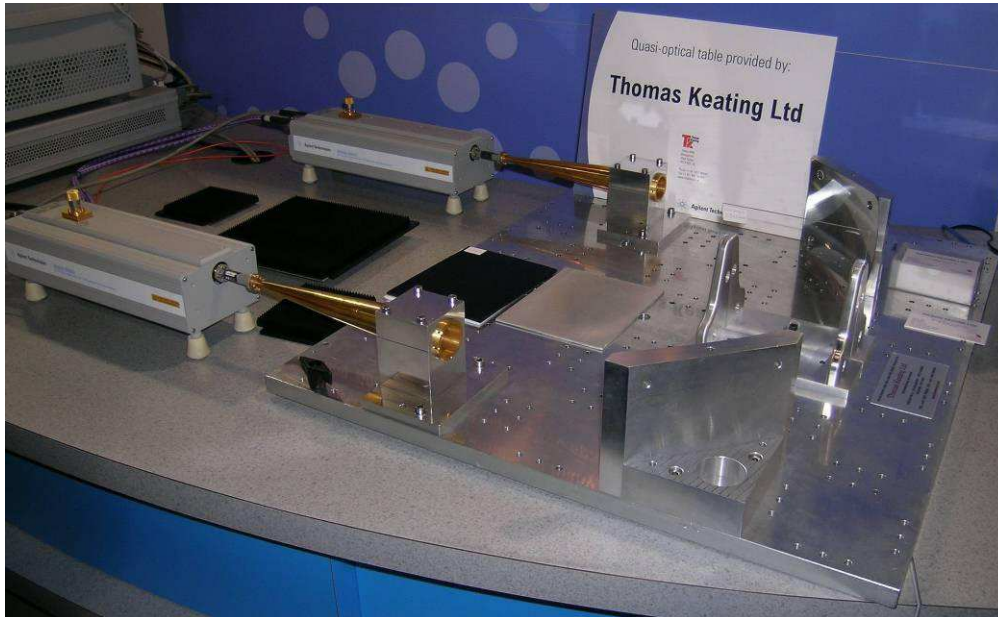
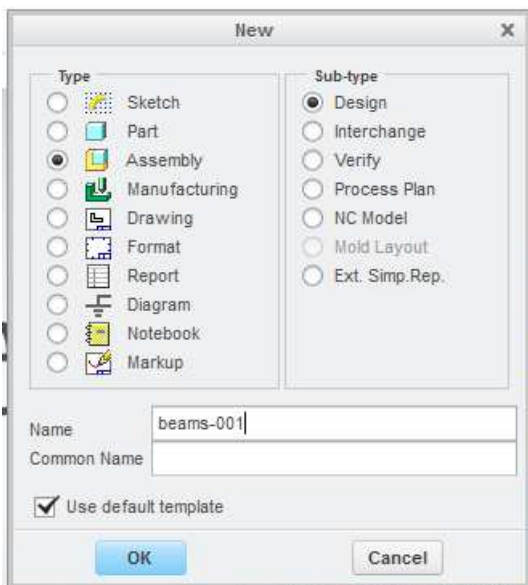

Figure 2-1 QO material test bench provided by Thomas Keating Ltd

### 2.1 CREATING A NEW ASSEMBLY

First of all, in order to display 3D GBM beams, you will need to create a new assembly. Once the beam assembly is complete, it can then be assembled into an optics assembly.



- ▶ Select 'File' from top left of screen
- ▶ Select 'New'
- ▶ Select 'Assembly' button
- ▶ Enter a name in name box (e.g. beams-001)
- ▶ Select 'OK'
- ▶ Then 'Save'

Figure 2-2 New Assembly dialog box

Once you have clicked 'OK' this will open a blank assembly window, and completes the assembly creation stage.

To save what you have done at any time - select the disc icon or from the 'File' drop down menu.

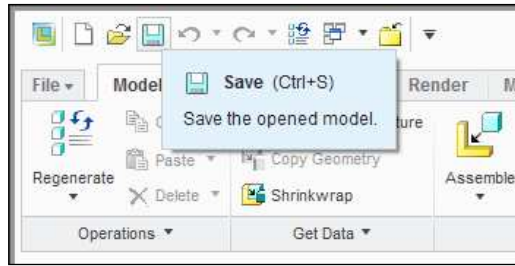

Figure 2-3 Creo Save icon

### 3 ASSEMBLE GBM COMPONENTS

Now that you have created an assembly, albeit blank (without beams), you can now start to assemble components; starting with your first beam.

#### 3.1 FIRST BEAM

- ▶ Select 'Assemble' icon to add first component to the assembly
- ▶ Select '**TK-GBM-BEAM-A\_xxx.prt**' from dialog box
- ▶ Select 'Open'
- ▶ Select 'Default' from 'Automatic' drop down menu
- ▶ Select green tick to finish

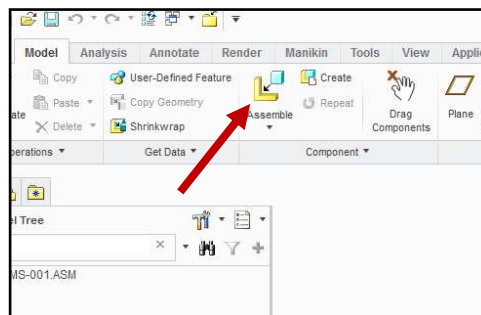

Figure 3-1 Assemble Icon

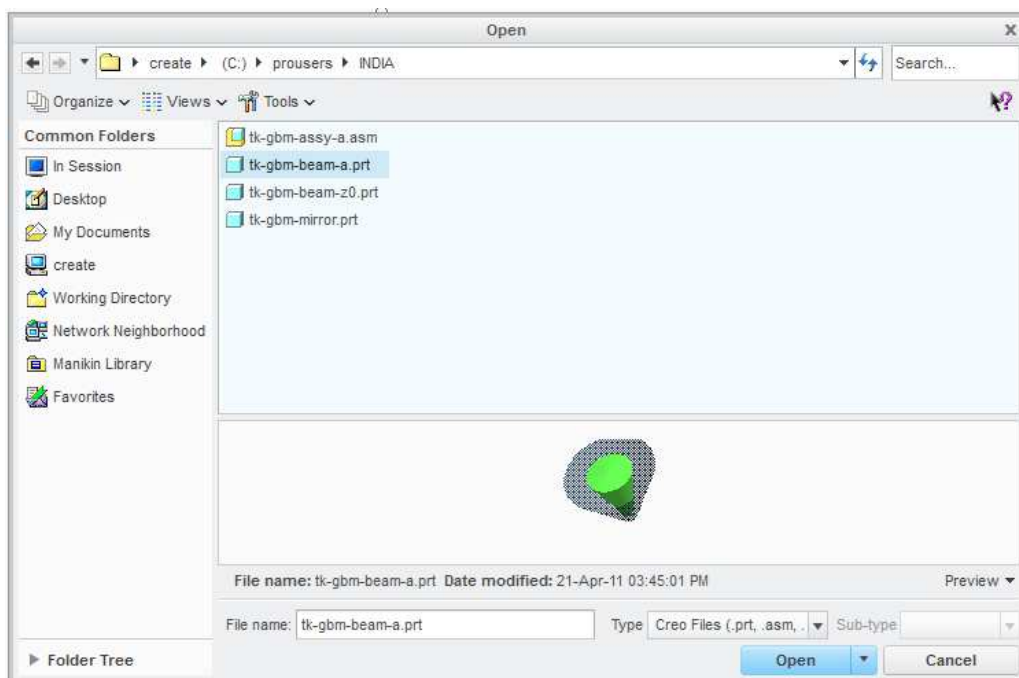



Figure 3-2 Assembly dialog box

Once you have clicked 'Open' the system will ask for your first beam (*TK-GBM-BEAM-A\_xxx.prt*) to be positioned.

As this is the first component in your 'BEAMS-001.ASM' you can select the '**Default**' location option from the 'Automatic' drop down menu, as shown below.

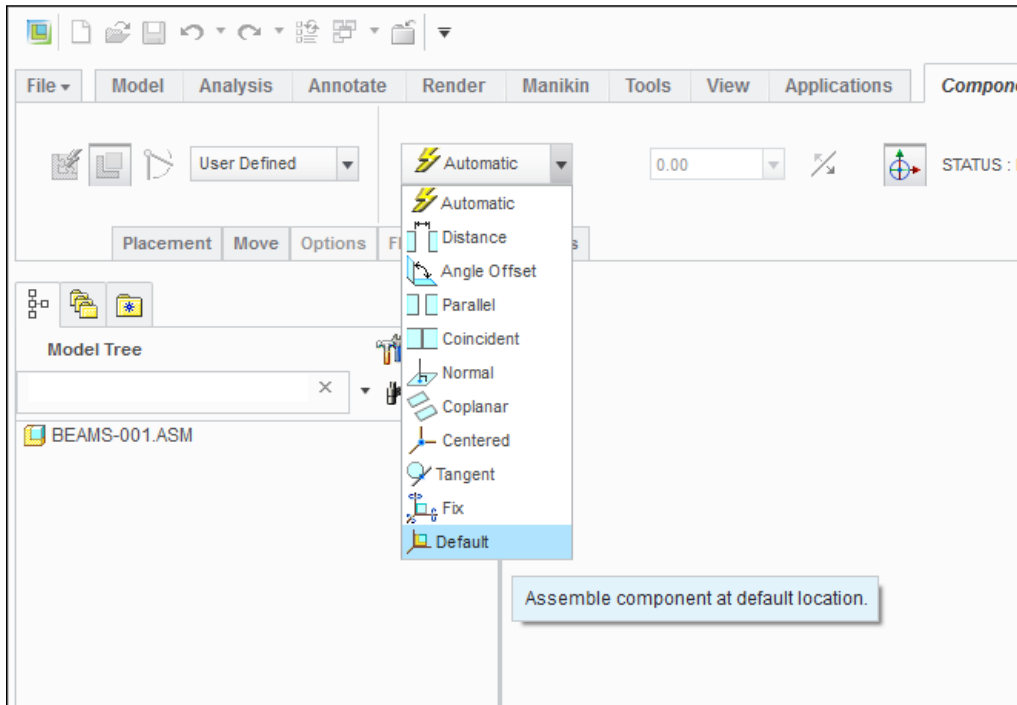

Figure 3-3 Select 'Default' from drop down menu

To complete the placement of your first beam, select the green tick from the top right hand of the screen.

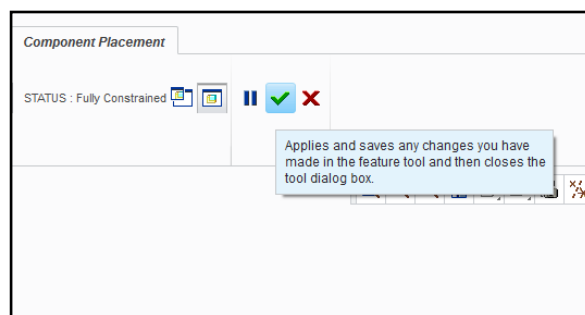

Figure 3-4 'Green tick' to finish placing the first beam

### 3.2 MIRROR ASSEMBLY

Now that you have your first beam in place, and your assembly file is saved, you can proceed to add the first focusing mirror onto the end of your first beam:

- ▶ Select 'Assemble' icon  to add focusing mirror to the assembly
- ▶ Select '**tk-gbm-mirror.prt**' from dialog box
- ▶ Select 'Open'

From the 'Placement' tab assemble '**tk-gbm-mirror.prt**':

- ▶ **Coincident:** 'Input-Plane' on mirror, then 'End-Beam' datum on beam
- ▶ **Change orientation**
- ▶ **Coincident:** Axis 'A\_2', then Axis 'A\_5' on mirror
- ▶ **Check:** 'Allow Assumptions'

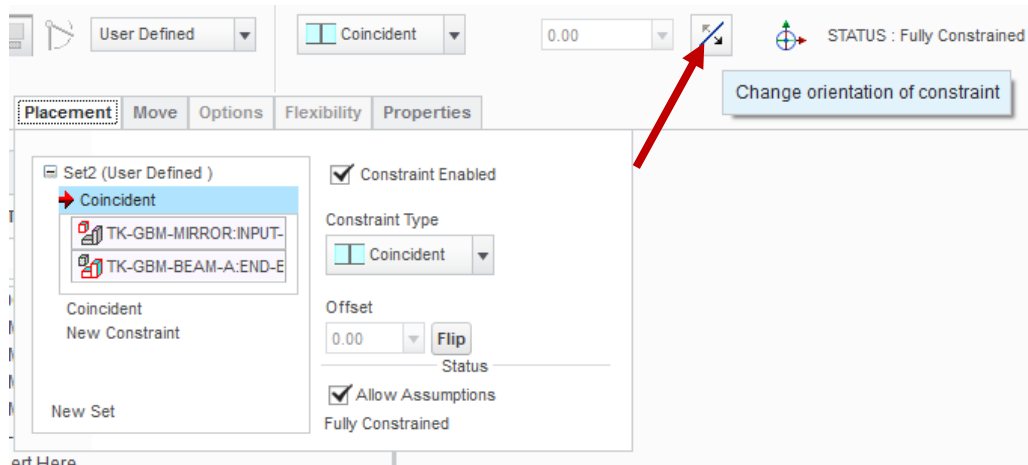



Figure 3-5 'Placement' dialog box showing mirror constraints -  
note check in 'Allow Assumptions' box

### 3.3 BEAM ASSEMBLY FROM A MIRROR

With a starting beam and mirror in place, you now need to assemble a beam onto the first mirror:

- ▶ Select 'Assemble' icon - 
- ▶ Select '**TK-GBM-BEAM-A\_xxx.prt**' from dialog box
- ▶ Select 'Open'

You now should now have a beam ready to be positioned onto the first mirror.  
From the 'Placement' tab assemble the 2nd beams:

- ▶ **Coincident:** 'BEAM-OUT' (datum) on beam, then 'MIRROR-OUT' (datum) on mirror
- ▶ **Change orientation:** depending on your layout
- ▶ **Coincident:** Axis 'A\_2', then Axis 'A\_8' on mirror
- ▶ **Check:** 'Allow Assumptions'

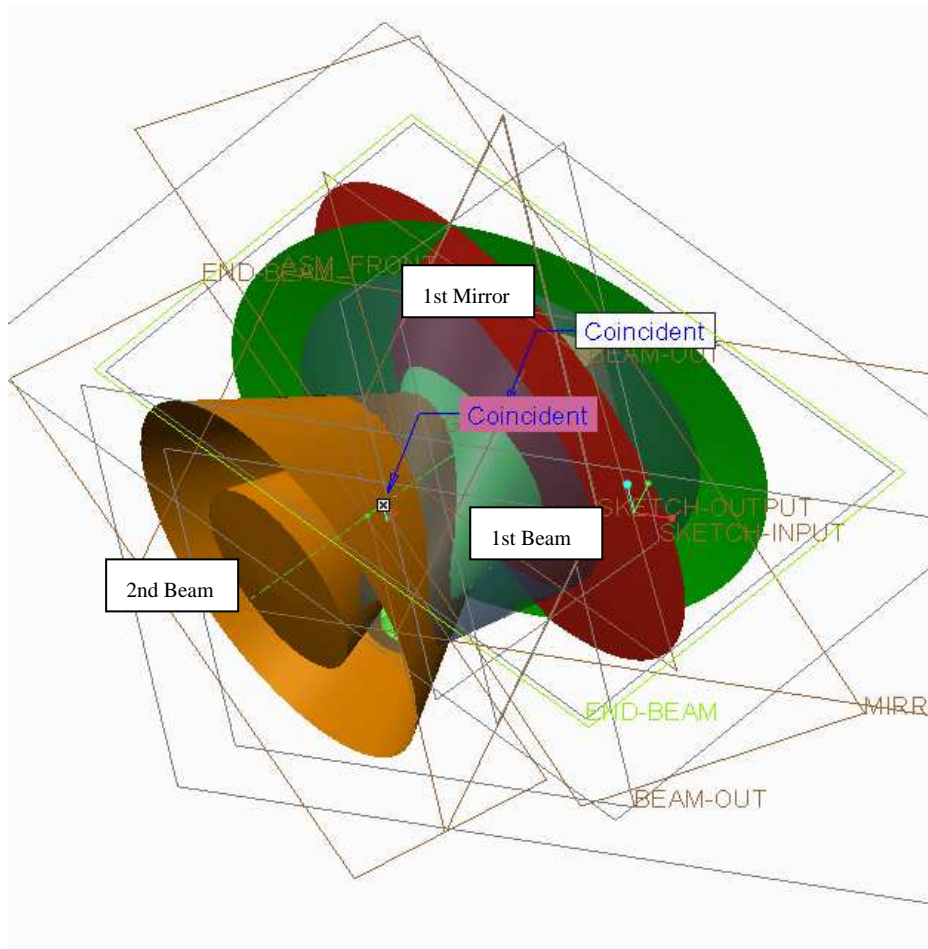
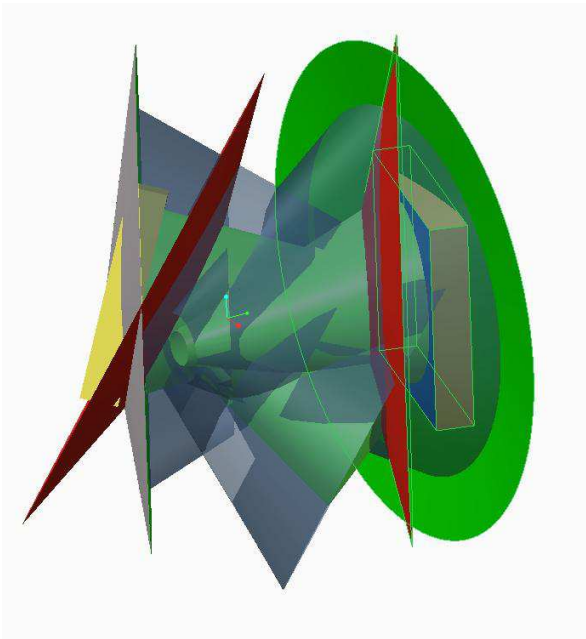

*Figure 3-6 Two 'Beams and Mirror' assembled*

Mirror and beam assembly can now be repeated depending on your layout.

### 3.4 FINISHED ASSEMBLY

To finish this assembly, one more mirror and beam are needed. Simply repeat steps 3.2 and 3.3



*Figure 3-7 Assembly now ready for flexibility*

Now that you have finished placing all of your mirrors and beams into the assembly, the next stage is to add flexibility into the models to able you to fully configure the layout.

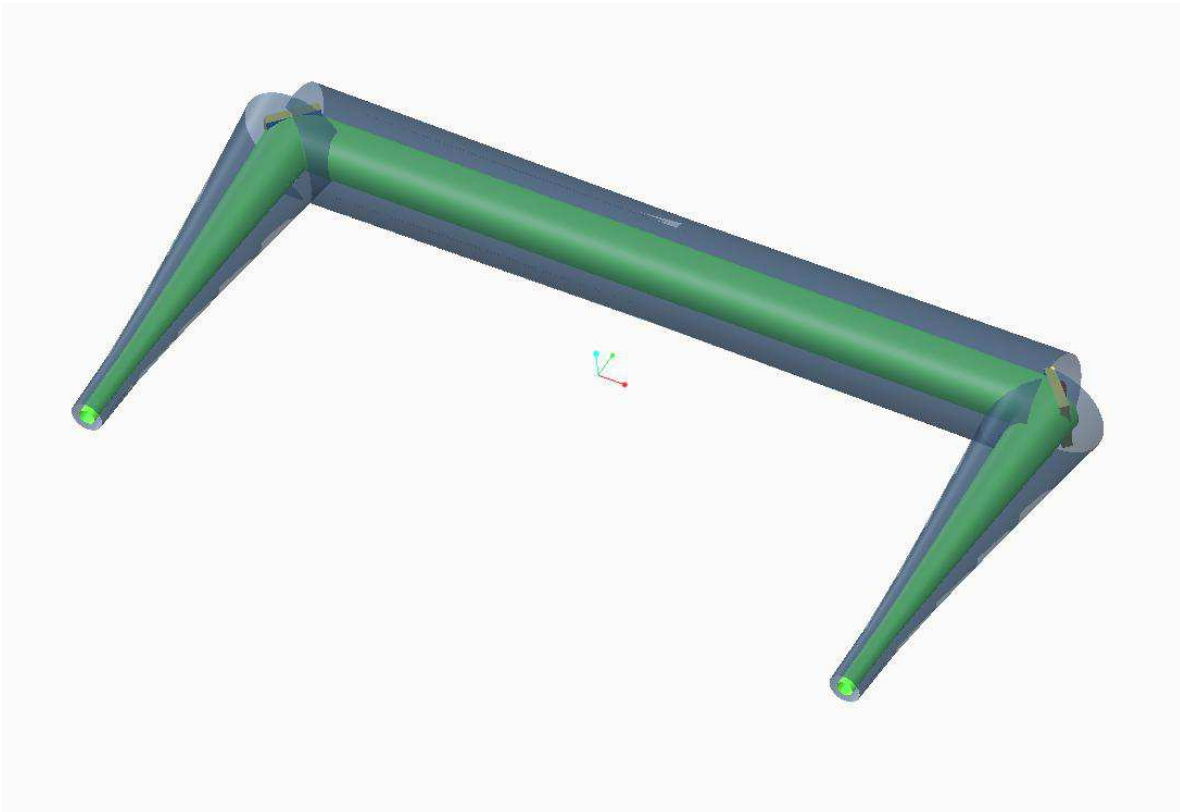

*Figure 3-8 Assembly after flexibility applied*

## 4 CONFIGURATION - ADDING FLEXIBILITY

With your basic layout laid down in an assembly, flexibility functionality is added to the beams and mirror models.

By making the part models flexible in an assembly, you're able to have multiple copies of the same model but with different dimensions and parameters such as beam length and focal length.

It is these flexible dimensions and parameters that are edited to correctly display your beam designs.

Wavelength will be a 'global' parameter and therefore not made flexible (see section 9).

### 4.1 BEAM PARAMETERS

The Pro/E part file '*TK-GBM-BEAM-A\_XXX.prt*' contains numerous construction points, parameters and relations in order to display a 3D GBM beam.

There are three parameters that need to be flexible:

- ▶ '**W1**' The Beamwidth radius (to 1/e amplitude level)
- ▶ '**W1-CUR**' The beam phase front curvature is indirectly provided by the distance of W1 - CUR - as shown in the diagram below<sup>2</sup>.
- ▶ '**Z2**' - Length along axis of propagation

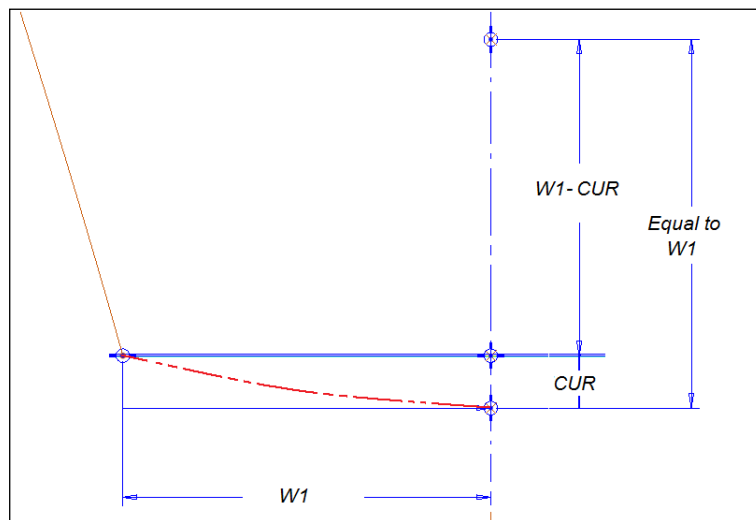

Figure 4-1 Beam Waist Input parameters

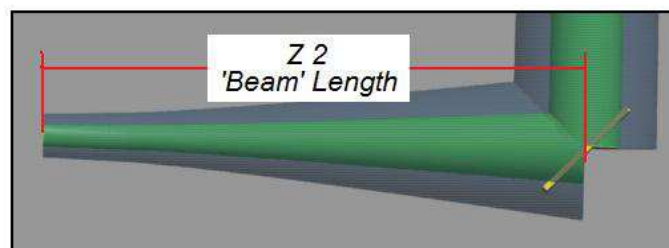

Figure 4-2 Propagating Beam length parameter - Z 2

<sup>2</sup> The curvature of the beam is needed to determine the propagation of the beam. Our approach is to provide this curvature via the phase cap error distance, CUR, subtracted from W1, the beamwidth. CUR and thereby the radius of curvature, R1, can be derived from this though  $R1 = \frac{CUR}{2} + \frac{(W1)^2}{2 \cdot CUR}$

## 4.2 MAKING BEAMS FLEXIBLE

- ▶ Right Mouse Button (RMB) click on '**TK-GBM-BEAM-A\_xxx.PRT**' and select '*Make Flexible*'

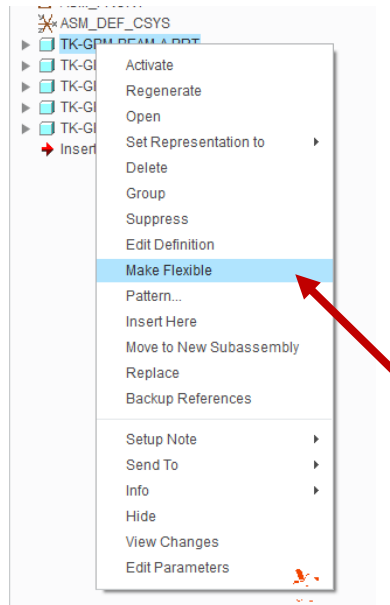

Figure 4-3 'Make Flexible' from model tree

- ▶ Select the inner beam surface '**GBM\_PROFILE**' - This will display all the dimensions used to create the selected surface.

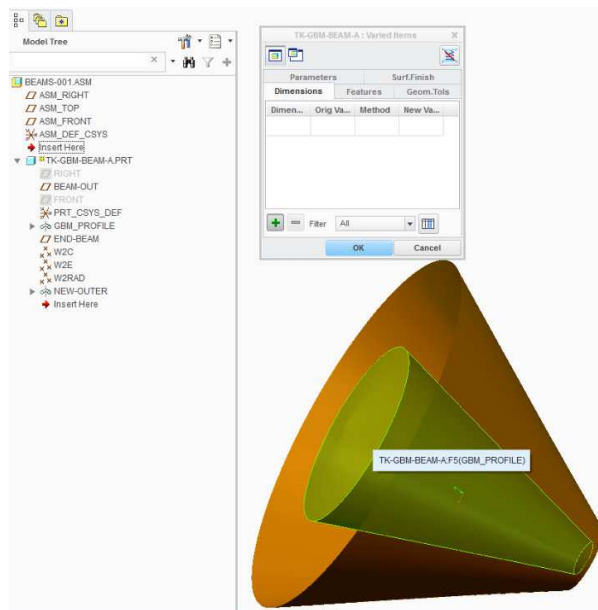

Figure 4-4 Adding beam dimension flexibility

- ▶ Select dimension '**W1**' d8 - Green plus - and enter new dimension in the 'New Value' box
- ▶ Select dimension '**W1-CUR**' d42- Green plus - and enter new dimension in the 'New Value' box

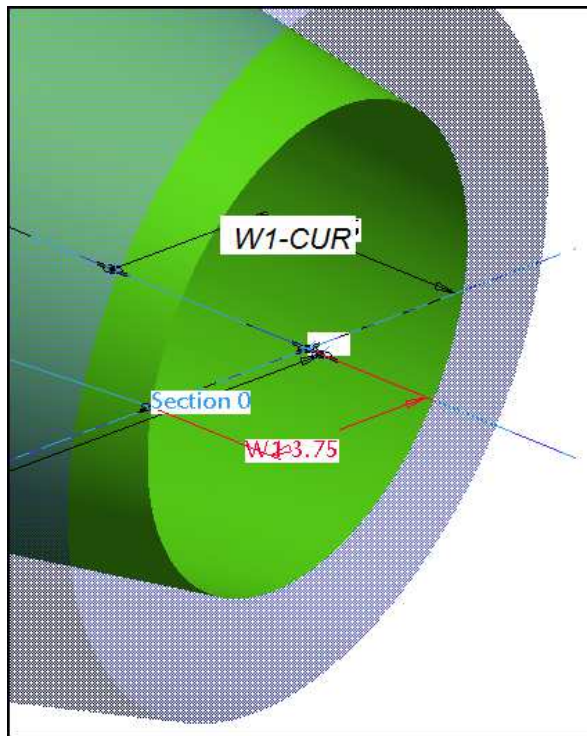

Figure 4-5 Beam waist at input

- ▶ Select 'Parameters' tab - then the green plus icon
- ▶ Select '**Z2**' - Insert Selected - and enter your chosen beam length in the 'New Value' box

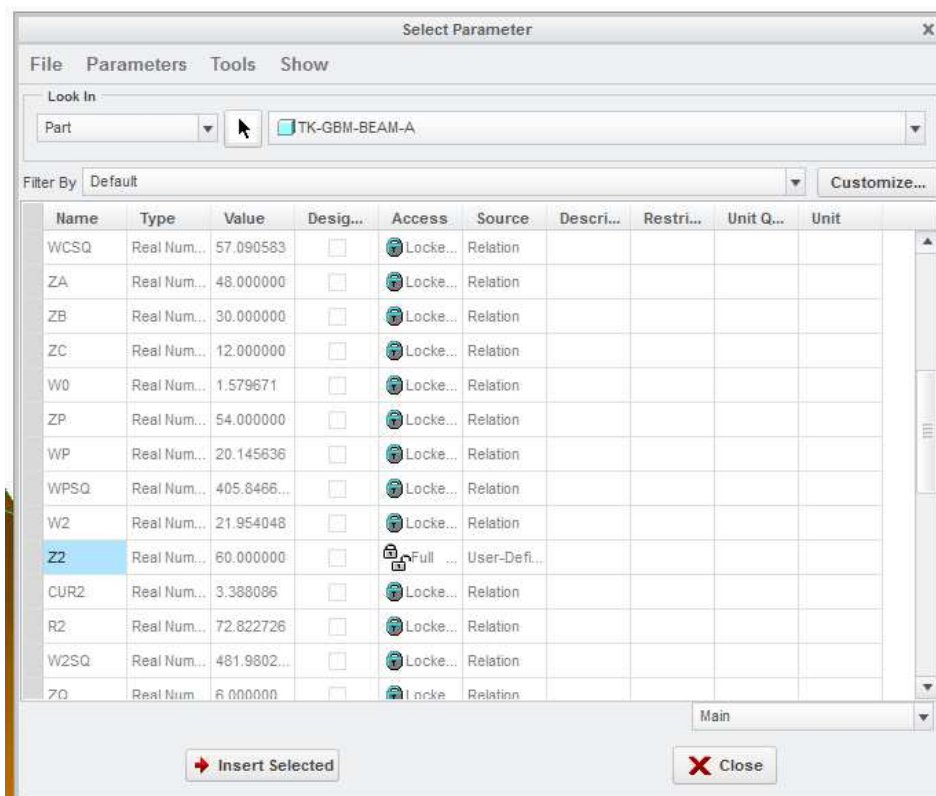

Figure 4-6 Parameter Dialog box

## 5 FOCUSING MIRROR

When dealing with the mirror model there are two main parameters we need to edit.

- ▶ Dimension 'd9' which is 90 degrees less the angle of incidence (the half bend angle)

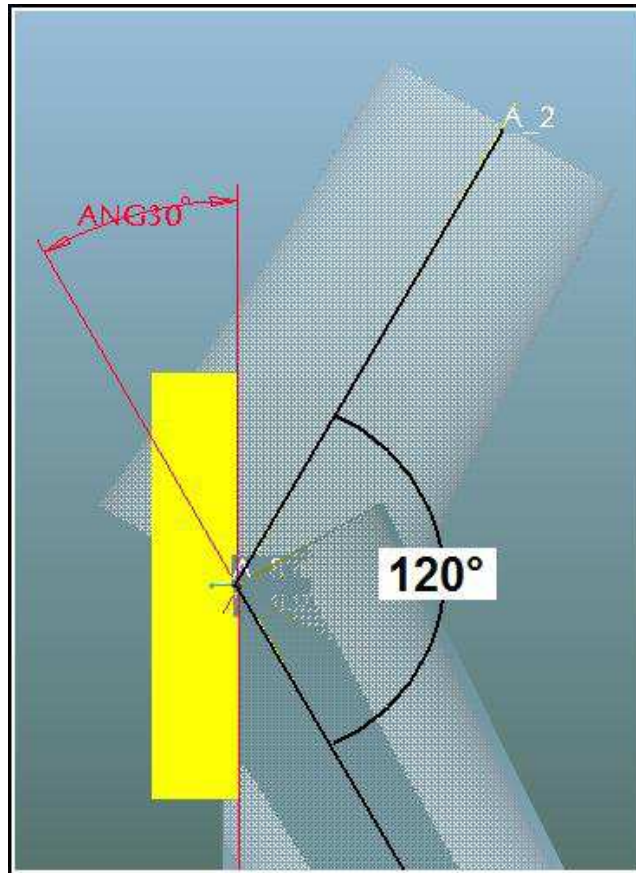

Figure 5-1 Editing the bend angle

- ▶ Parameter 'f' - Focal length

For flat mirrors you should enter a very long focal length – say 100,000mm



## 6 MAKING MIRRORS FLEXIBLE

As we have shown with the beams, the mirrors need to have flexibility added to them:

- ▶ RMB click on '**TK-GBM-MIRROR.PRT**' and select '*Make Flexible*'
- ▶ Select '**SKETCH-INPUT**' Plane - pick dimension '**ANG**' and enter 90 degrees less the angle of incidence (the half bend angle)
- ▶ Select dimension '**d40**' from the '**INPUT**' revolve geometry
- ▶ Select dimension '**d42**' from the '**INPUT**' revolve geometry
- ▶ For '**d40**' change method from 'By value' to 'Distance'

To match the input beam with an output beam we need the following:

- ▶ Measure distance between datum points '**W2C**' and '**W2E**' (on beam)
- ▶ For '**d42**' change method from '**By value**' to '**Distance**'
- ▶ Measure distance between datum points '**W2C**' and '**W2RAD**' (on beam)

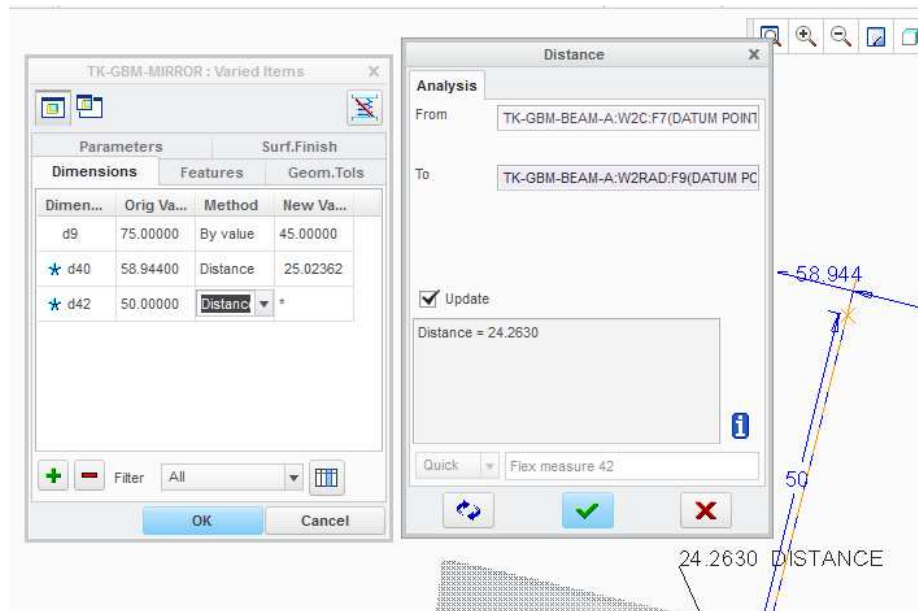
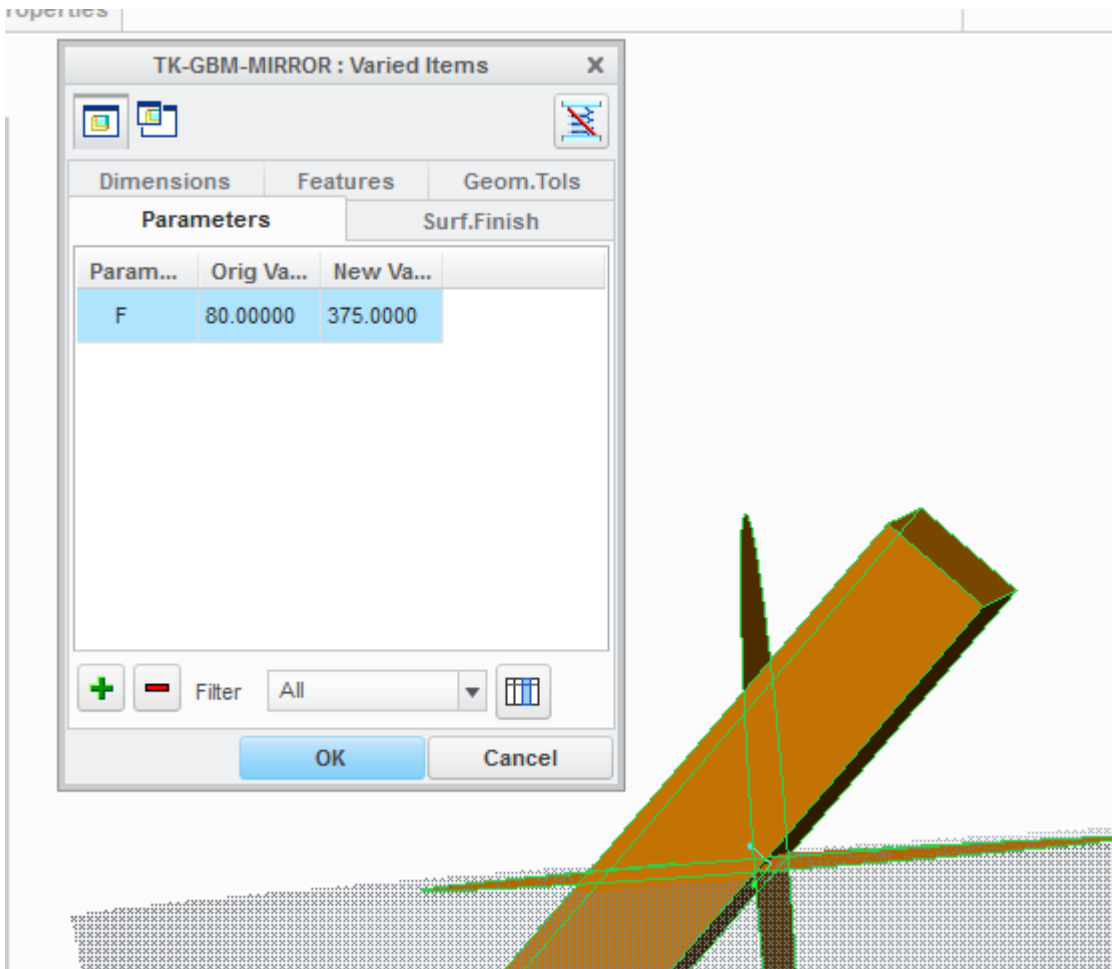

Figure 6-1 Measured 'Distance' between datum points

- ▶ Select 'Parameters' tab - then the green plus icon
- ▶ Select '**F**' - Insert Selected - and enter your chosen focal length in the 'New Value' box



*Figure 6-2 Parameter 'F'-focal length*

## 7 OUTPUT MATCHED BEAM

The second of the assembled beams needs to have its input matched to that of the output beam coming off of the focusing mirror.

Adding flexibility again we can measure this:

- ▶ RMB click on 2nd '**TK-GBM-BEAM-A\_xxx.PRT**' and select '*Make Flexible*'

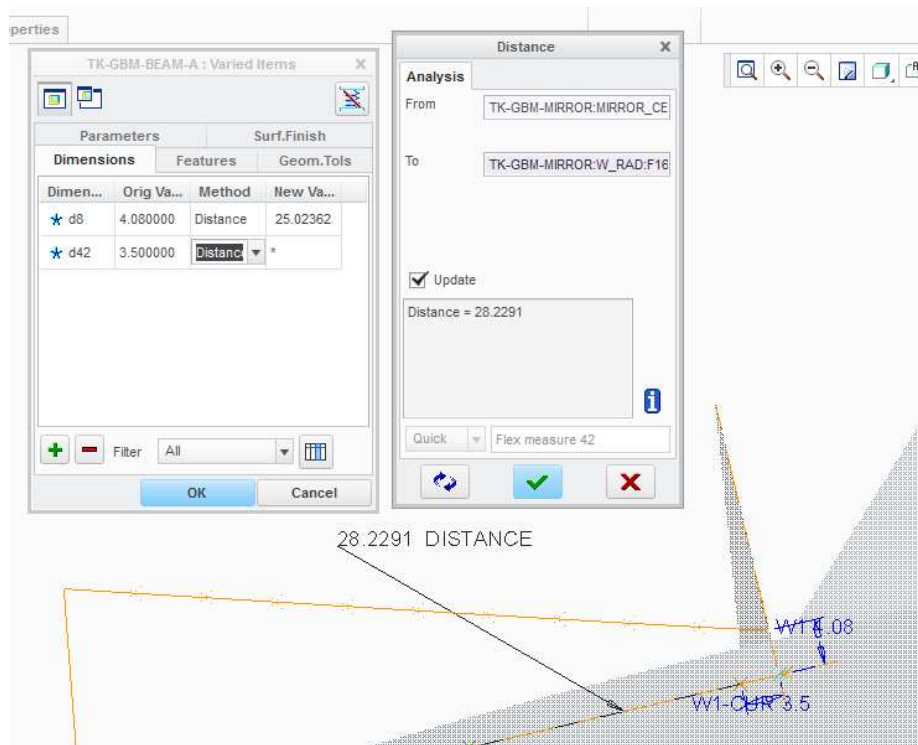

Figure 7-1 Matching output beam

- ▶ Select dimension '**W1**' d8 - Green plus - and change method to distance
- ▶ Measure distance between datum points 'MIRROR\_CENTRE' and 'W\_EDGE'
- ▶ Select dimension '**W1-CUR**' d42- Green plus - and change method to distance
- ▶ Measure distance between datum points 'MIRROR\_CENTRE' and 'W\_RAD'

And as before:

- ▶ Select 'Parameters' tab - then the green plus icon
- ▶ Select '**Z2**' - Insert Selected - and enter your chosen beam length in the 'New Value' box

## 8 FINAL BEAM (TK-GBM-BEAM-A\_XXX)

- ▶ RMB click on 'TK-gbm-beam-A\_xxx.PRT' and select 'Make Flexible'
- ▶ Select the beam surface
- ▶ Select dimension 'W1' d8 - Green plus
- ▶ Select dimension 'd42' - Green plus
- ▶ Measure distance between datum points 'W\_EDGE' and 'MIRROR\_CENTRE' (on mirror)
- ▶ Measure distance between datum points 'W\_RAD' and 'MIRROR\_CENTRE' (on mirror)
- ▶ Select 'Parameters' tab - then the green plus icon
- ▶ Select 'Z2' - Insert Selected - and enter your chosen beam length in the 'New Value' box

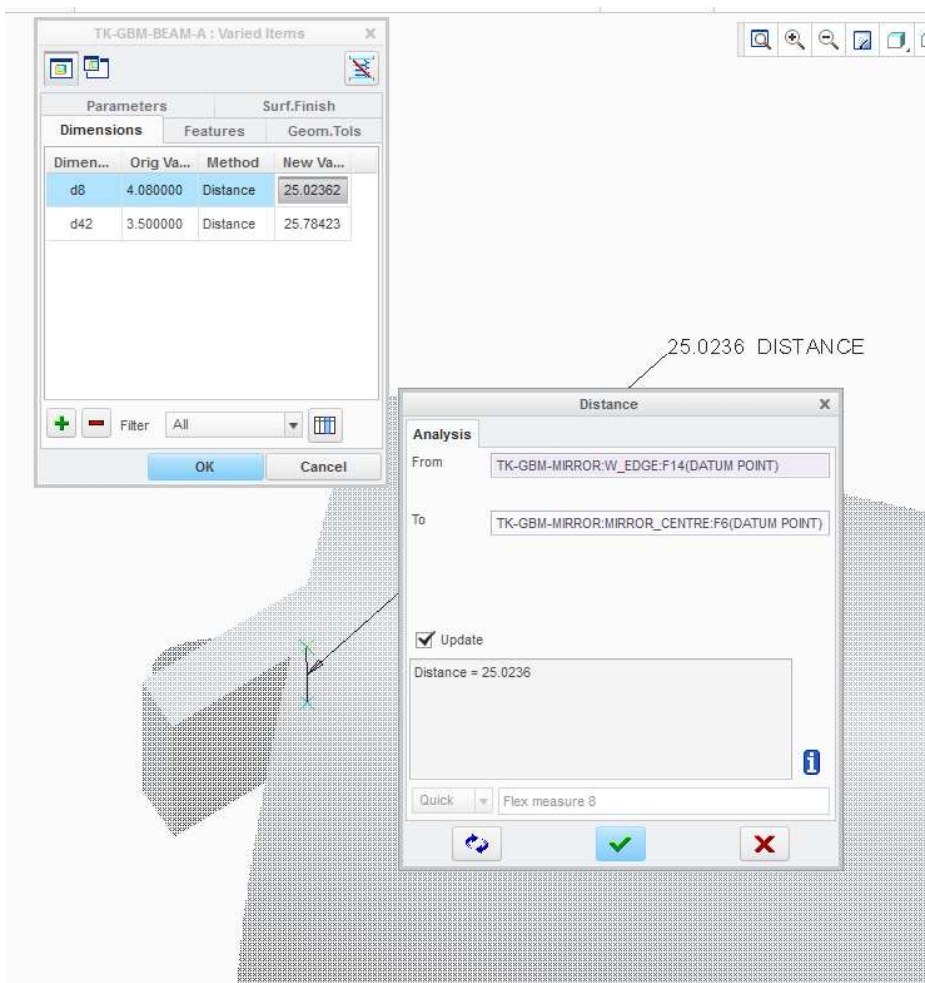

Figure 8-1 Distance parameter

## 9 WAVELENGTH PARAMETER

Once you are happy with your layout the wavelength can be applied by adjusting the 'part' parameter from the assembly parameter dialog box.

- ▶ Select 'tools' then parameters:

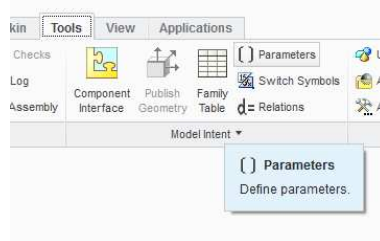

Figure 9-1 Parameters under Tools tab in assembly mode

- ▶ Under 'Look In' scroll down to select 'Part'

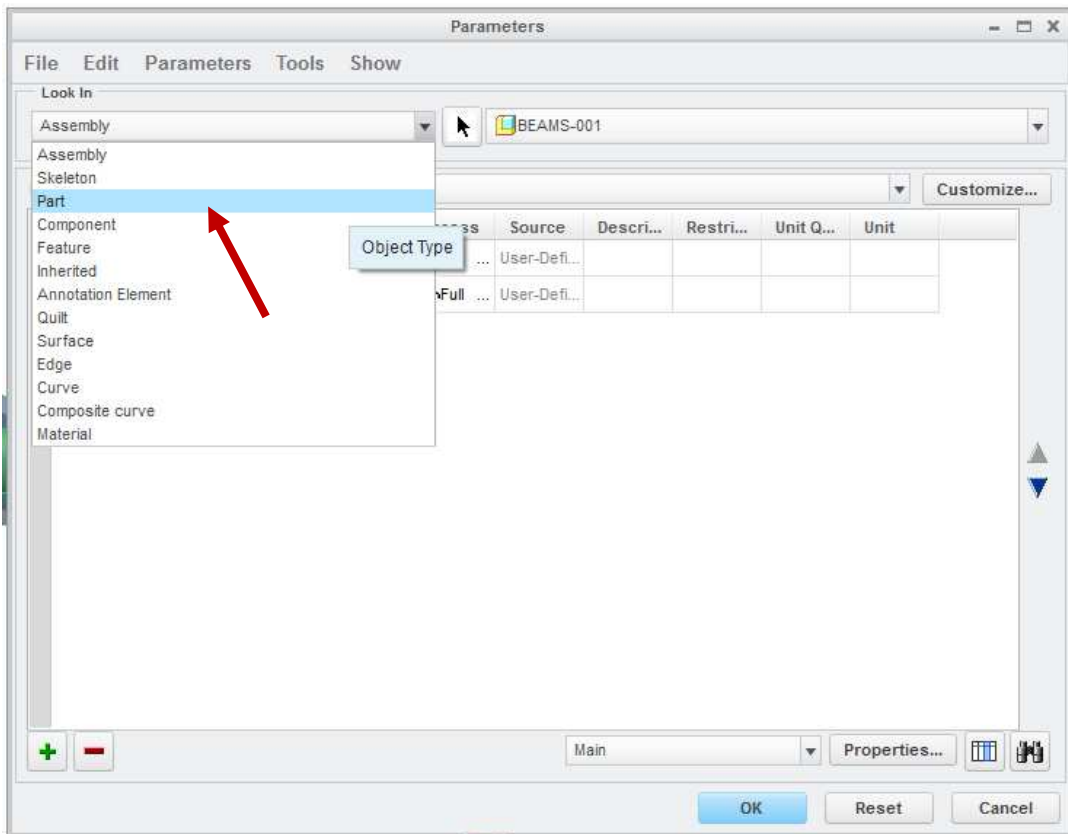

Figure 9-2 Scroll down 'Look In' to find 'Part'

- ▶ Scroll down to find 'WAVE', then change the value to your wavelength (mm)

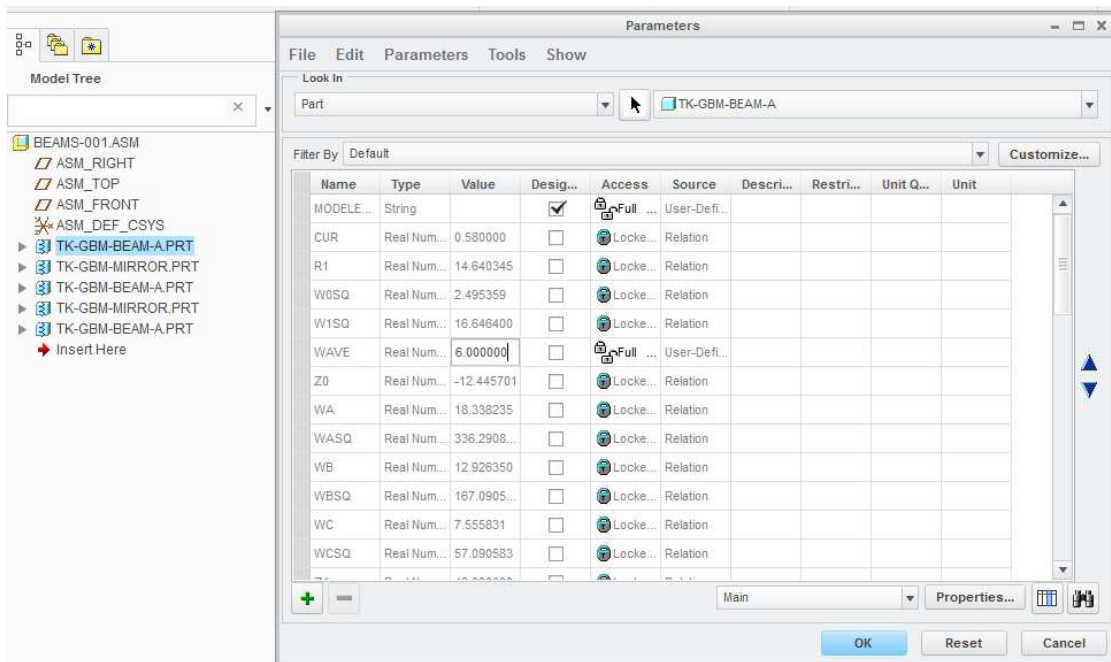

Figure 9-3 'Part' section of parameters dialog box - Enter new value for wavelength

- ▶ Confirm with 'OK' and regenerate

## 10 ANALYSIS DISPLAY

Analysis of the GBM can be displayed by switching the 3D annotations on.

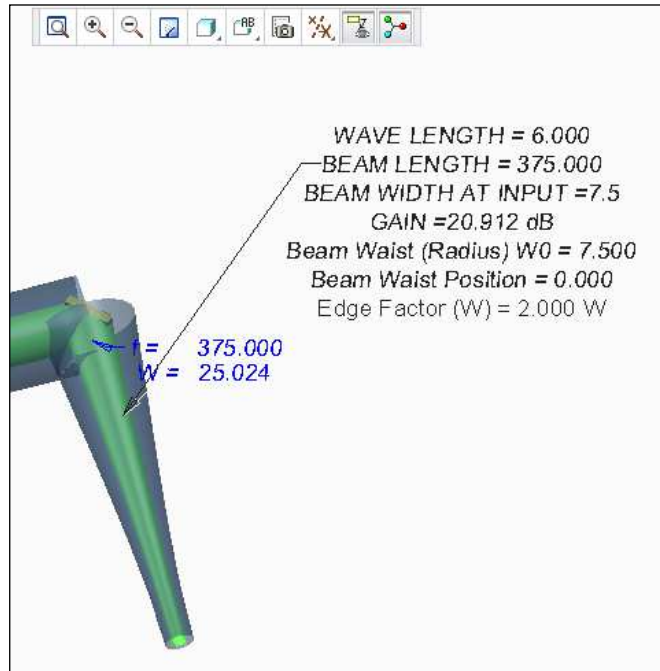

Figure 10-1 Single beam analysis displayed

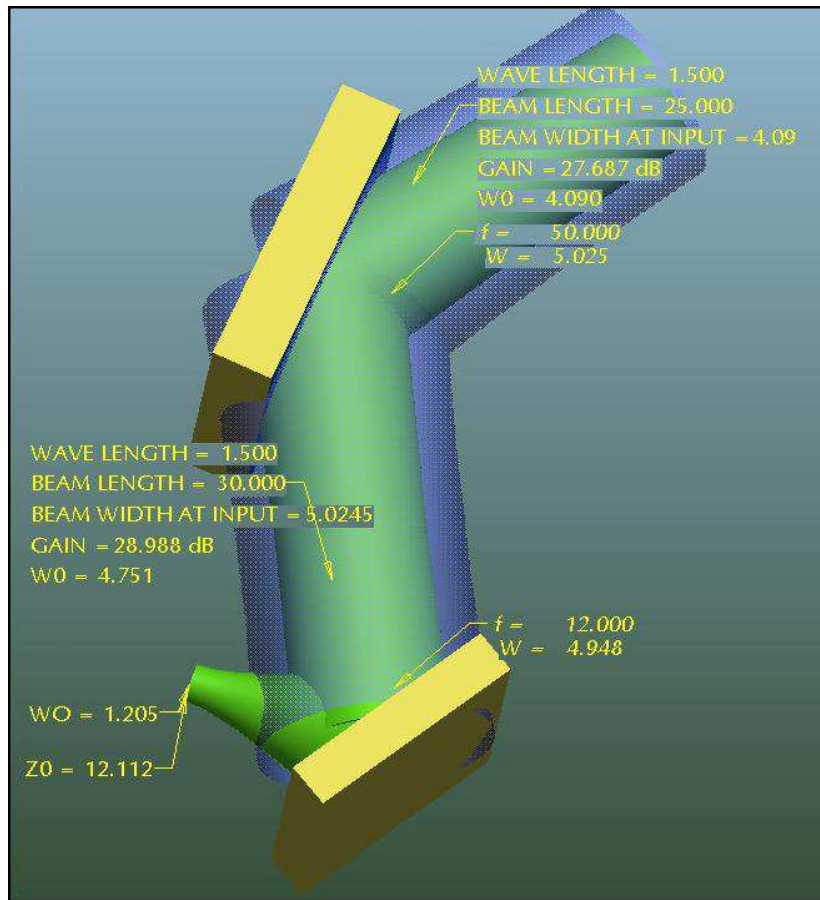
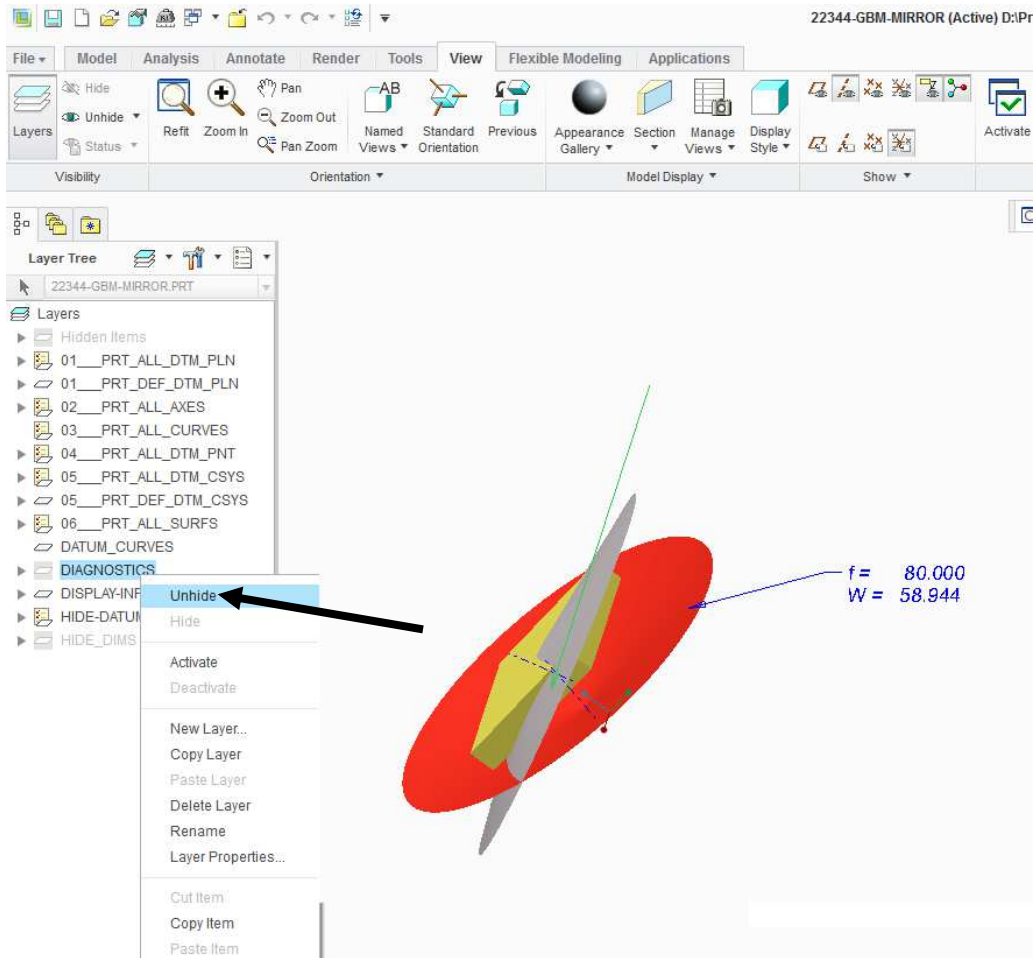
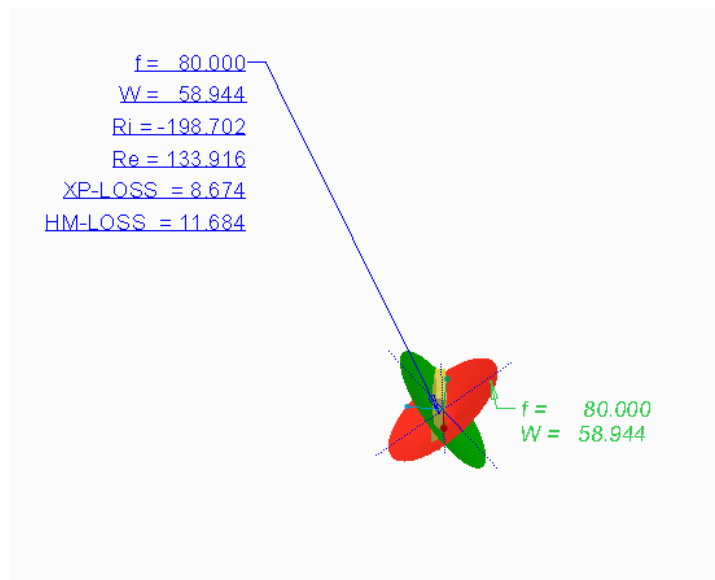

Figure 10-2 Full beam path analysis

To display the full data available



In Layers you will need to un-hide the DIAGNOSTICS layer to display the full GBM data given on a mirror (see section 1.3)



## 11 BEAM WAIST FINDING BEAM

When your beam layout design requires knowledge of the beam waist position (Z0) then use the model 'TK-GBM-BEAM-Z0\_xxx.PRT' instead of 'TK-GBM-BEAM-A\_xxx.PRT'

- ▶ Select 'Assemble' icon - 



- ▶ Select '**TK-GBM-BEAM-Z0\_xxx.prt**' from dialog box
- ▶ Select 'Open'

You now should now have the final beam ready to be positioned onto your last mirror.

From the 'Placement' tab assemble:

- ▶ **Coincident:** 'BEAM-OUT' (datum) on beam, to 'MIRROR-OUT' (datum) on mirror
- ▶ **Coincident:** Axis 'A\_2', then Axis 'A\_8' on mirror
- ▶ **Check:** 'Allow Assumptions'

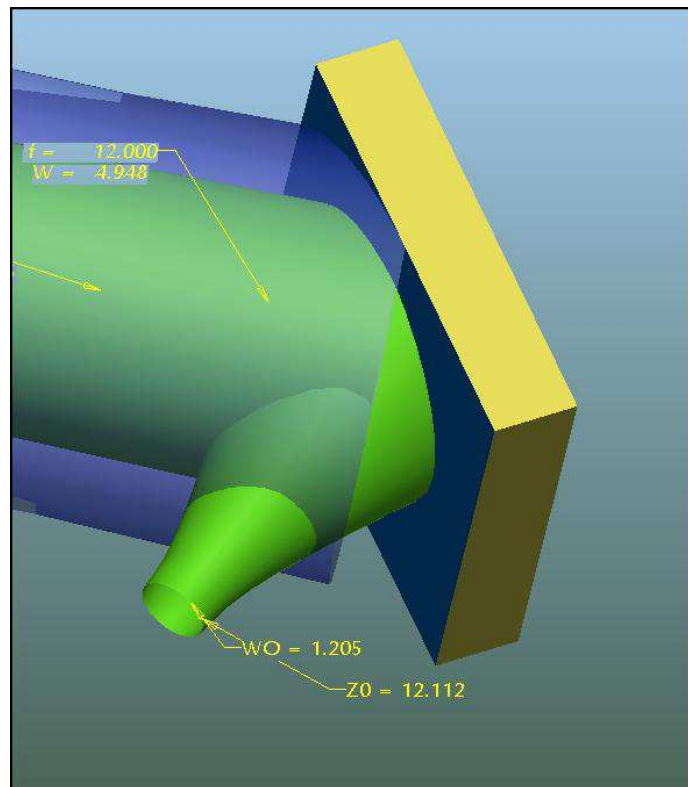

Figure 11-1 Beam waist of (Radius) 1.205mm at a distance of 12.112mm (Z0) from mirror impact point.

- ▶ Remember to turn on the 3D annotation tool to display data. 